

## LONGITUDINAL-SECTION

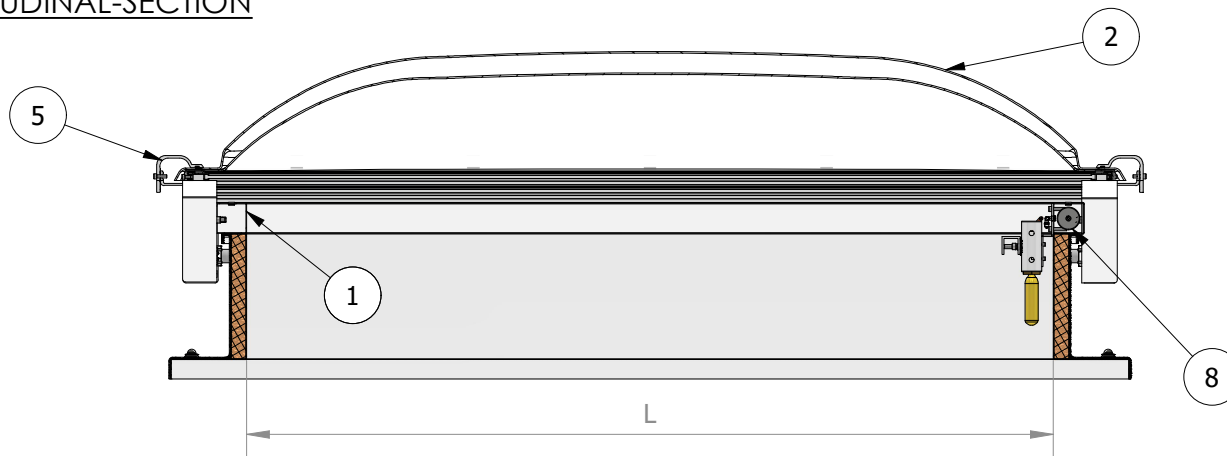

## CROSS-SECTION

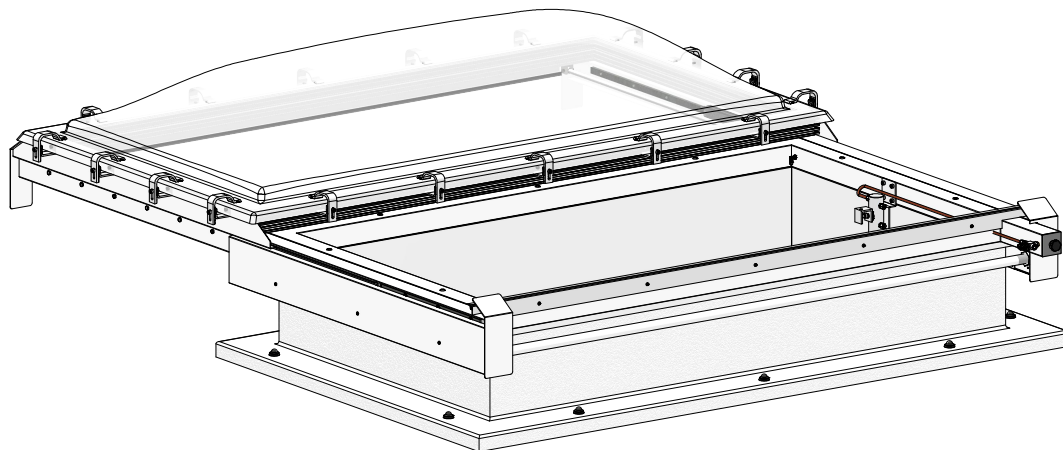
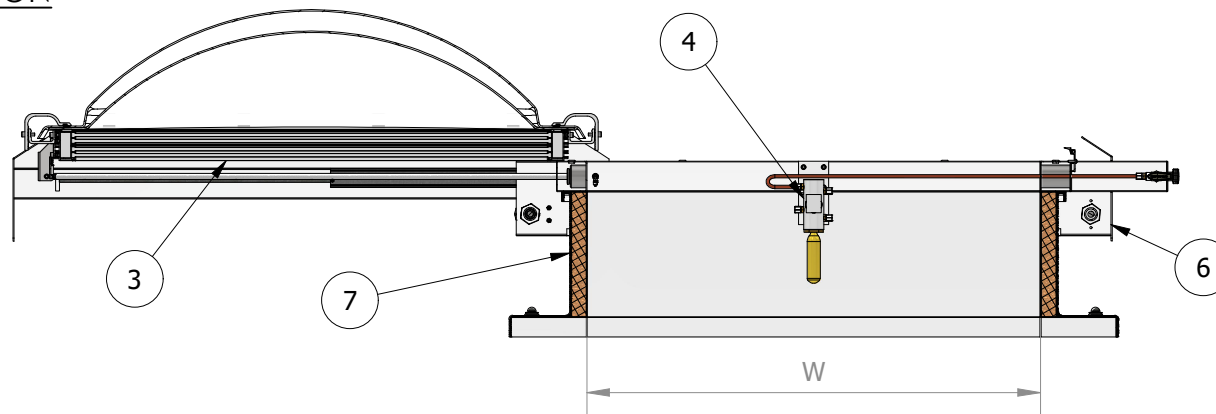

## SPECIFICATIONS

1. INTERNAL WHITE POWDER COATED METAL FRAME (OTHER RAL COLORS AVAILABLE)
2. THERMOFORMED DOME MADE OF SINGLE/DOUBLE/TRIPLE LAYER IN PLASTIC (POLYCARBONATE OR ACRYLIC)
3. MOBILE FRAME IN ALUMINIUM - MILL FINISH
4. THERMAL VALVE
5. ALUMINIUM FIXING CLAMPS
6. EXTERNAL WHITE POWDER COATED METAL PROFILES (OTHER RAL COLORS AVAILABLE)
7. UPSTAND (CAN BE DONE BY OTHERS ACCORDING TO TELFORM'S SPECIFICATIONS)
8. PNEUMATIC CYLINDER

L = OPENING LENGTH (MAX 250 cm FOR SMOKE VENTILATION)  
 W = OPENING WIDTH (MAX 130 cm FOR SMOKE VENTILATION)  
 H = UPSTAND HEIGHT (MIN 25 cm FOR SMOKE VENTILATION)

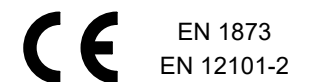

**TELFORM**

TELFORM NEW GENERATION srl

Via delle Mammole 22 - 70026 Modugno (BA - ITALY)

TEL +39 080 5375656

FAX +39 080 5375098

E-MAIL info@telform.it

WEB www.telform.it

VITAL DOME S

Scale	Format	Description:
1 : 15	ISO A4	SLIDING SKYLIGHT

This drawing is the property of Telform NG srl and incorporates information which is proprietary. Publication and/or public distribution in whole or in part is expressly prohibited without the prior written consent of Telform NG srl. The information contained herein remains the property of Telform NG srl. All rights reserved.